

Service Manual

Minuteman[®]
Excellence Meets Clean

**All E17BD, E17TD, E20S, E20BD, E20TD,
E20C, H20BD, H20TD E26ECOS and
E26ECO Automatic Scrubbers**



For:
Training
Troubleshooting
Adjustments

Revised 01/20/2022

Contents

1	Safety	Page 5
2	Technical Specifications	Page 6
	2.1 Dimensions E17BD & E20BD	Page 7
	2.2 Dimensions E17TD & E20TD	Page 8
3	Maintenance Intervals	Page 9
	3.1 Customer Maintenance	Page 10
	3.2 Maintenance I after every 125 hours of operation	Page 11
	3.3 Maintenance II after every 250 hours of operation	Page 12
	3.4 Maintenance S after every 500 hours of operation	Page 13
4	Batteries and Wiring	Page 14
5	Recovery Float and Gasket	Page 15
6	Lubrication	Page 16
7	Charge Indicator Version 1	Page 17
8	On Board Chargers (957760 and 957761) (Ver. 1 & 2)	Page 18
	8.1 Programming the 957745 Charger	Page 19
	8.2 Charger Settings (957745)	Page 20
	8.3 Battery Charger Trouble Shooting	Page 21
	8.4 Battery Charger Error Codes 957745 (Ver. 1)	Page 25
	8.5 Programming The 957760 & 957761 Charger (Ver. 2)	Page 26
	8.6 Charger Error Codes 957760 & 957761	Page 27

Contents

	8.7 Prime Chargers	Page 29
	8.8 Prime Charging Status Indicator	Page 30
	8.9 Prime Charger Fault Codes	Page 31
	8.10 IEB Charger	Page 32
	8.11 IEB Charger Status Indicator	Page 33
	8.12 IEB Charging Profiles	Page 34
	8.13 IEB Programming	Page 35
	8.14 IEB Programming Continued	Page 36
9	Battery and Error Code Indicator	Page 37
	9.1 E17TD and E20TD Error Codes	Page 38
10	Trouble Brush Motor Circuit	Page 43
	10.1 Trouble Brush Motor Controller (Sport only)	Page 44
11	Squeegee Adjustment (Curved)	Page 45
	11.1 Squeegee Adjustment	Page 46
	11.2 Squeegee Caster Adjustment	Page 47
	11.3 Squeegee Caster Adjustment	Page 48
	11.4 Squeegee Caster Adjustment	Page 49
12	Maintaining Deep Cycle Wet Batteries	Page 50
13	Load Testing The Batteries	Page 52
14	Hydrometer Testing	Page 53

Contents

15	Transporting the Machine	Page 56
16	Key Switch	Page 57
17	Solution Filter (Version 1)	Page 58
	17.1 Solution Filter (Version 2)	Page 59
18	Testing the Main Power Relay	Page 60
19	Trouble Shooting the Drive Circuit	Page 65
	19.1 Trouble Shooting The Traction Drive Switch	Page 66
	19.2 Trouble Shooting – Vacuum Motor Circuit	Page 67
	19.3 Trouble Shooting – Vacuum Relay	Page 68
	19.4 Testing the Drive System Potentiometer	Page 69
20	Current Draw of Motors	Page 70
21	Notes	Page 71

1. Safety

1. **Stop the machine only on level surfaces.**
2. **Avoid moving parts. Do not wear loose jackets, shirts, or sleeves when working on machine.**
3. **Avoid contact with battery acid. Battery acid can cause burns. When working on or around batteries, wear protective clothing and safety glasses. Remove metal jewelry. Do not lay tools or metal objects on top of the batteries.**
4. **Do not clean machine with a pressure washer.**
5. **Only authorized personnel should perform repairs and maintenance.**
6. **Use only Minuteman genuine replacement parts.**
8. **Do not use machine around flammable substances.**
9. **The batteries should be charged only in well ventilated areas.**
10. **Always disconnect the battery pack from the machine and the A.C cord the from outlet, when servicing the machine.**

2. Technical Specifications



E17BD, E20

Specifications

	E17	E20
Cleaning path width	17 in (43 cm)	20 in (51 cm)
Squeegee width Curved	30 in (76 cm)	34 in (86 cm)
Squeegee width Straight	33 in (83.82cm)	33 in (83.82cm)
Theoretical productivity (Brush Drive)	12,750 ft ² /hr (1,185 m ²)	15,000 ft ² /hr (1,394 m ²)
Theoretical productivity (Traction Drive)	23,120 ft ² / hr (2,147 m ²)	27,200 ft ² /hr (2,527 m ²)
Working speed (Brush Drive)	1.7 mph (2.7 km per hr)	1.7 mph (2.7 km per hr)
Working speed (Traction Drive)	3.1 mph (5 km per hr)	3.1 mph (5 km per hr)
Rated voltage	24 volts	24 volts
Vacuum flow	65 cfm (110 m ³ /hr)	65 cfm (110 m3/hr)
Vacuum waterlift	45 inches (112mbar)	45 inches (112mbar)
Vacuum power	.60 hp (450 W)	.60 hp (450 W)
Drive motor power (TD only)	1/5 HP (150 W)	1/5 HP (150 W)
Brush type	Disc	Disc
Brush motor(s) power	3/4 HP	3/4 HP
Number of brushes	1	1
Brush RPM	180 RPM	180 RPM
Aqua-Stop equipped	Coming Soon	Coming Soon
Solution capacity	12Gal (45 liters)	12 Gal (45 liters)
Recovery capacity	13 Gal (49 liters)	13 Gal (49 liters)
Weight with batteries (BD only)	306 lbs (139 kg)	313 lbs (142 kg)
Weight without batteries (BD only)	196 lbs (89 kg)	203lbs (92 kg)
Weight with batteries (TD only)	365 lbs (166 kg)	372 lbs (169 kg)
Weight without batteries (TD only)	231 lbs (105 kg)	238 lbs (108 kg)
Dimensions (LxWxH)	44.4 x 18.8 x 42.3 (112.8 x 47.8 x 107.4 cm)	47.4 x 21.3 x 42.3 (120.4 x 54.1 107.4 cm)

2.1 Dimensions E17BD & E20 BD

With a Straight Squeegee

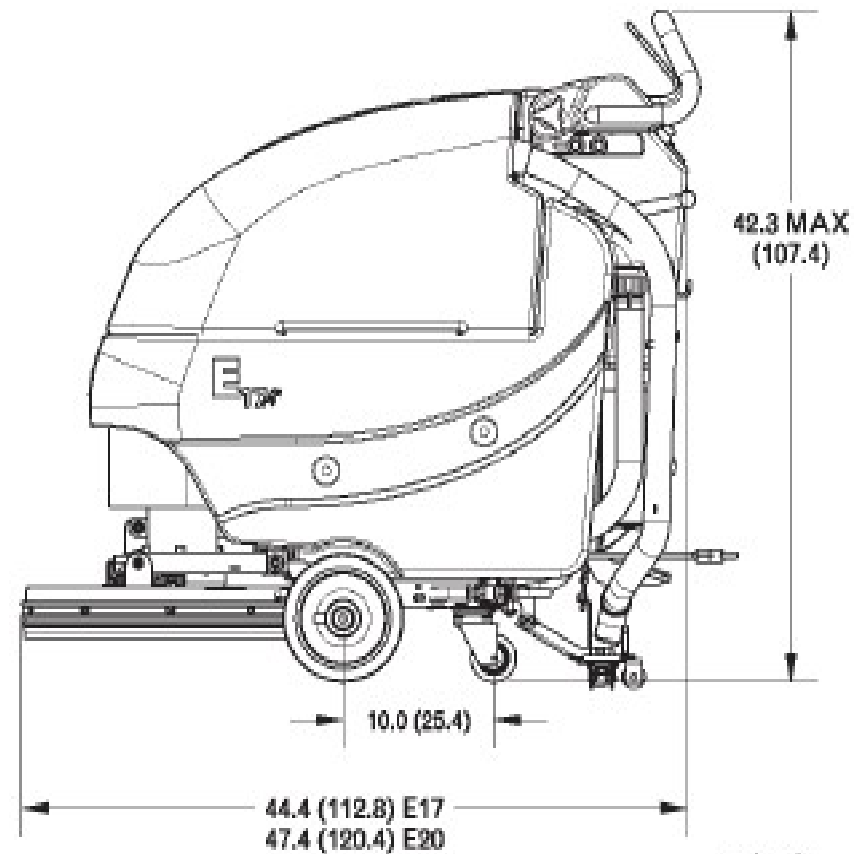
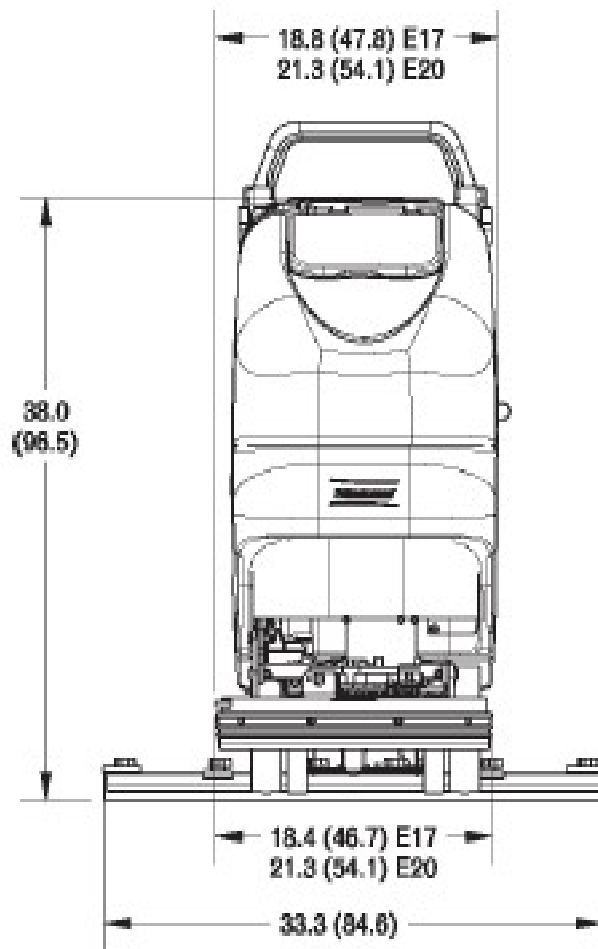

in (cm)

2.2 Dimensions (E17 & E20)

With Curved Squeegee

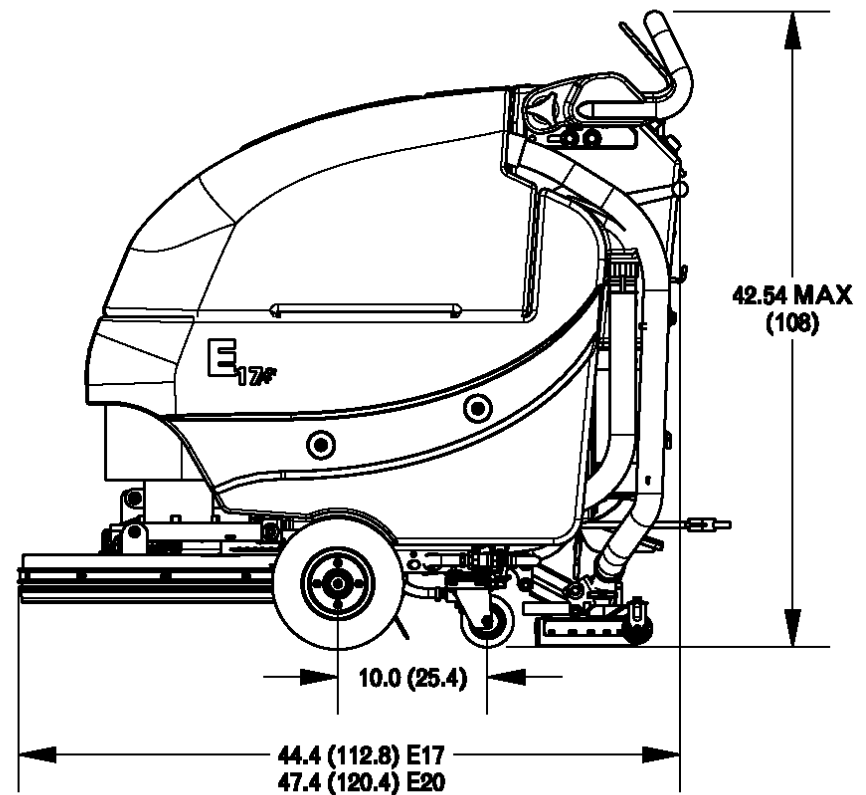
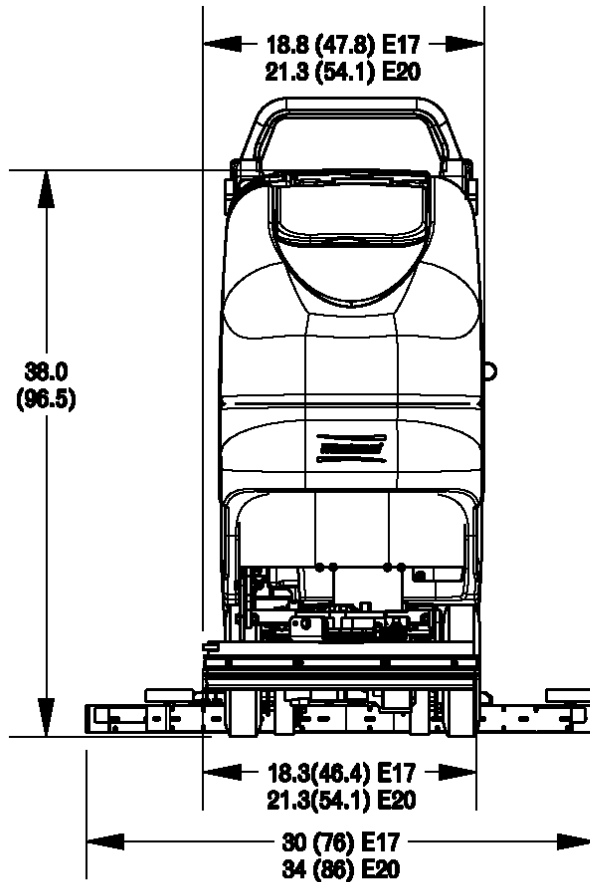

in (cm)

3. Maintenance Intervals



•Maintenance Intervals:

In a modular structure, the Minuteman System Maintenance determines the specific technical procedures to be performed and sets the time interval between the two maintenance cycles.

For each of the maintenance cycle, the replaceable parts are determined as well. Further details described in the specific chapters.

•Minuteman System Maintenance K:

To be performed by the customer (in daily or weekly intervals) according to the maintenance and care instructions as specified in the operating instructions.

The operator must be professionally instructed after delivery of the machine by selling dealer.

•Minuteman System Maintenance I: (after every 125 hours of operation)

To be performed an authorized Minuteman Service Center in accordance with the machine-specific system maintenance.

•Minuteman System Maintenance II: (after every 250 hours of operation)

To be performed an authorized Minuteman Service Center in accordance with the machine-specific system maintenance.

•Minuteman System Maintenance S: (after every 500 hours of operation, safety check) To be performed by an authorized Minuteman Service Center in accordance with the machine-specific system maintenance.

3.1 Minuteman System Maintenance K **Minuteman**[®]

Excellence Meets Clean

To be performed by the customer/user	Interval	
	Daily	Weekly
Fill the clean water tank and mix the proper amount and type of cleaning solution.	O	
Charger the batteries.	O	
Check the brush head, Clean if needed with a damp cloth. Do not get water inside the motor.	O	
Check the squeegee, clean if needed	O	
Check the lid gasket on the recovery tank.	O	
Empty and flush the recovery tank with clean water.	O	
Clean the filter/float inside the recovery tank.	O	
Check the water levels of all the batteries. Add distilled water, if needed. Do not over fill.	O	
Check the pads and brushes for wear. Replace if needed.		O
Check the squeegee hose for clogs, damage and wear. Replace if needed		O
Check the squeegee rubbers for cuts and wear. Flip the blade(s) over or replace.		O
Check the solution filter. Clean if needed.		O
Flush the clean water solution tank with warm water.		O
Test all the functions of the machine.		O

3.2 Minuteman System Maintenance I



To Be Performed By An Authorized Service Center	Interval
	Every 125 hours of operation
Perform the Minuteman System Maintenance I	0
Check the battery charger. Make sure it is functioning correctly.	0
Check the recovery lid gasket. Replace if needed.	0
Lubricate the brush lift linkages with grease. Use a small brush.	0
Check for loose hardware, tighten if needed.	0
Check the tire pressure on pneumatic wheels at 65 psi, if equipped.	0
Lubricate the squeegee linkages with grease. Use a small brush.	0
Inspect the entire machine for damage, wear and proper operation.	0

3.3 Minuteman System Maintenance II



To Be Performed By An Authorized Service Center	Interval
	Every 250 hours of operation
Perform the Minuteman System Maintenance II	0
Inspect the caster wheels for wear and damage. Repair, if needed.	0
Inspect the carbon brushes for wear in the transaxle. Replace, if needed.	0
Inspect the recovery drain hose for wear or damage. Replace, if needed.	0
Inspect the brush bumper rollers for wear or damage. Replace, if needed.	0
Inspect the carbon brushes in the brush motors for wear. Blow out with compressed air.	0
Inspect the recovery hose for damage or wear. Replace, if needed.	0
Inspect the squeegee assembly for proper adjustment. Repair, if needed.	0
Test the machine for proper operation.	0

3.4 Minuteman System Maintenance S



To Be Performed By An Authorized Service Center	Interval
	Every 500 hours of operation
Perform the Minuteman System Maintenance check	0
Replace the carbon brushes in the transaxle.	0
Replace the carbon brushes in the brush motors.	0
Test the machine for proper operation.	0

4. Batteries & Wiring

•Battery Compartment

- The battery compartment is located under the recovery tank. The battery compartment can be accessed for servicing and maintenance by tilting the recovery tank. Make sure the recovery tank is has been drained before tilting.
- The battery compartment contains two 12 volt batteries connected in series.
- Connect the batteries according the battery wiring diagram to the right.
- The recommended batteries are two 12 volt, 115 Ah deep cycle battery part number 956712 for the Wet Lead Acid type or 12 volt 100Ah AGM Maintenance Free is part number 956100. Do not use Automotive or Marine type batteries.
- When changing the type of battery (going to Gel from Wet Lead Acid or visa versa) the battery charger will need to be programmed accordingly. See Section 8.1 on Programming the Charger.

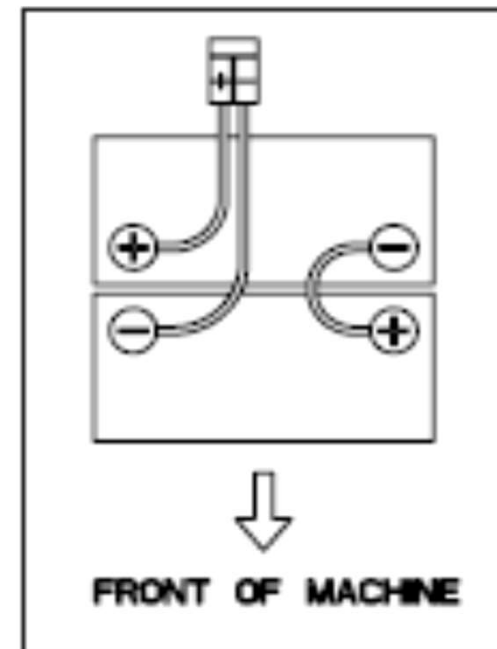

5. Recovery Float

- **The Recovery Float and Filter** is located inside of the tank,
- The filter should be checked after each use and cleaned if needed.
- Remove the three screws and the cover, to access screen float for more extensive cleaning.
- Failure to do so will reduce the vacuum performance of the machine.
- Using the machine without it in place or picking up dry material will damage the vacuum motor.

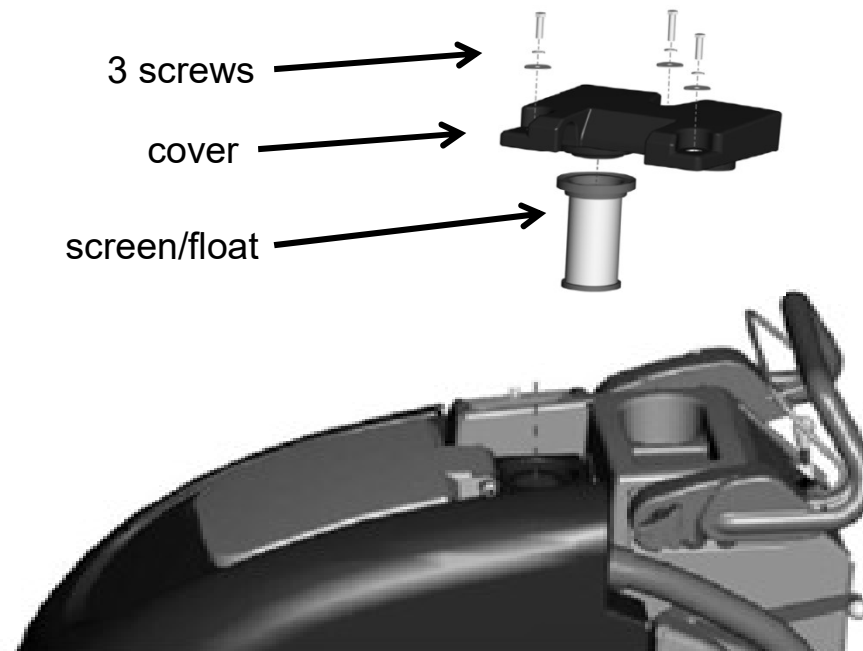

6. Lubrication

Regularly scheduled lubrication of certain machine parts should be performed to insure trouble-free operation of the machine. *Apply a generous amount of grease into the fittings on the machine until grease seeps out around the bearings. Wipe excessive grease off with a towel.*

The grease points are listed below:

- 1. Rear squeegee caster wheel axle (2)*
- 2. Rear squeegee caster swivel (2)*

Apply lubricant to:

- 1. The rear squeegee pivot points*
- 2. The scrub deck linkages.*

7. Charging Indicator (Version 1)

- The indicator will light during the charging process.
- The red light indicates, the batteries need a full charge.
- The yellow light indicates, the batteries have received 80% of their charge.
- The green light indicates, the batteries are fully charged.
- The red light is flashing, indicates the charger has detected a fault in the batteries. (See Section 8.6)
Applies to the 957760 and 957761 chargers only.



8. On Board Chargers (Version 1 and 2) **Minuteman**[®] *Excellence Meets Clean*

- The Minuteman on board chargers are capable of being programmed to charge lead acid wet or gel type maintenance free batteries.
- The on board charger has a variety of other programming settings.
- Use caution when making changes. Incorrect settings may cause the charger to malfunction and or damage the batteries.
- The 957745 charger (on left) has a series of dip switches located under the front decal that can be used to change the settings.
- The 957760 and 957761 chargers (on right) has a accessible rotary switch at the bottom of the charger.



957745 Charger



957760 & 957761 Chargers

8.1 Programming the 957745 Charger



1. Remove the large rear metal cover on rear the machine.
2. Locate the battery charger.
3. To access the Dip Switches, carefully peel the decal back on the front of the charger. Start at the bottom left side and peel up. (Removing the plastic charger cover is not necessary.) Use caution not to damage the decal.
4. There is a series of eight Dip Switches located under the decal.
5. Each switch is numbered 1 through 8.

Dip Switches 1 to 4 are for setting the type of battery.

Type of Battery	Switch 1	Switch 2	Switch 3	Switch 4
Lead Acid Wet Batteries	ON	ON	OFF	ON
AGM	ON	OFF	OFF	ON
Gel and Maintenance Free	ON	OFF	OFF	ON

8.2 Charger Settings (957745)

The dip Switches 5,6 and 7 are for selecting the amperage output of the charger. Use the 12 amp. setting only. * Note: The dip switch # 7 does not have any function at this time.

Current (Amperage Output)	Switch 5	Switch 6	Switch 7
4 AMPS	ON	ON	NA
8 AMPS	OFF	ON	NA
10 AMPS	ON	OFF	NA
—————> 12 AMPS	OFF	OFF	ON

Dip Switch 8 is to select the output voltage, either 12 or 24 volt. Use the 24 volt setting only.

Voltage Output	Switch 8
12 Volts	ON
—————> 24 Volts	OFF

8.3 Battery Charger Trouble Shooting



Version 1 and 2 Chargers

Trouble Shooting

1. Does the battery charger turn on when plugged into the A.C. outlet?
2. Can you hear the cooling fan turn on? If not, check the A.C. outlet for power.
3. Try a different outlet, if needed.
4. If it still doesn't turn on, inspect the A.C. cord. Repair if needed.
5. Inspect the A.C. cord.
6. If the A.C. cord is Ok, check to see if the battery connector has been plugged in to the machine's connector.
6. Inspect the battery cables. Make sure they are clean and tight.
7. Test the voltage of the batteries; it must be above two volts minimum, before the charger will turn on.
8. If everything above checks OK, and the charger still doesn't turn on or doesn't have any output, replace the battery charger.

8.3 Battery Charger Trouble Shooting



The Charger Turns On (957745 Charger)

1. If the charger appears to turn on, remove the rear metal cover on the rear of the machine.
2. The charger's display should be lighted, when plugged in the A.C. outlet. If not, replace the charger.
3. Check for errors on the chargers display (957745 only).
4. Press the number 5 on the charger decal (957745 only).
5. This will display different pieces of information about the charging process such as errors (957745 only). (see error list), battery voltage, output amperage, hours of charging and estimated amp hour of battery and wattage.
6. The voltage and amperage output should start to climb after a few minutes of starting the charger, unless batteries are still hot from charging. If not, replace the charger.

The Charger Turns On (957760 & 957761 Chargers)

1. Check for errors on the charging indicator on the rear of the machine. See section 8.6 "Battery Charger Error Codes".
2. Inspect the A.C. power cord and plug for damage.
3. Test the outlet for A.C. power.
4. If no errors are displayed on the LED indicator. Test the output of the charger. The battery voltage and output amperage should start to rise within a few minutes of starting up the charger.
5. Once the voltage reaches 28.8 volts the amperage should decrease until the amperage reaches about 3.5 amps.

Note: The charger will not restart if the battery voltage is too high from being charged recently. Allow time for batteries to cool, before attempting to re-start the charger.

8.3 Battery Charger Trouble Shooting



How the smart chargers work

The charger is programmable for wet, gel and AGM battery types.

Phase one: The charger is designed to put full output of 10 to 12 amps until the battery voltage reaches 28.8 volts for the first phase (red LED), otherwise it will time out. The maximum time limit for wet batteries is 12 hours for setting 1 and 15 hours for setting 2. Gel batteries have a 11 hour limit for the first phase.

Note: The first phase is when heavy and prolonged gassing can occur, if one or more cells are not reaching adequate voltage in the designated time programmed into the charger.

Phase two: The 28.8 volts is maintained (yellow LED) until the output current decreases to 3.5 -4.7 amps for wet batteries, then voltage should rise until it reaches 32.4 volts. The green LED (full charge) should light.

Wet batteries have a time limit of 5 hours for phase two.

Gel batteries will receive 28.8 volts until the chargers output reaches .5 amps (green LED, full charge).

Maintenance Charge: Once the batteries reach the full charge status, the charger will maintain (float/maintenance charge) the batteries at 26.4 volts for wet batteries and 27.3 volts for gel batteries, provided the charger is plugged into the A.C. outlet. Note: This will prevent the batteries from discharging, if the machine is not used for long periods of time.

8.3 Charger Trouble Shooting

(Excessive Gassing or Water Consumption in Batteries)

1. If the charger appears to be charging and excessive gassing or water consumption had been or is occurring in the batteries.
 2. Check the following:
 3. **A.** Have the batteries been maintained on a consistent basis? Failure to maintain batteries will shorten their life and reduce their performance.
 - B.** Test the batteries with a hydrometer. The batteries should be fully charged and cooled for 2 hours after charging, before testing. Top the batteries off with distilled water prior to charging, if needed. Do not over fill.
 - C.** Compare the cell readings of all the cells in each battery.
- The greater the variation between cells in any one battery, the greater loss of running time. A battery with variations of .040 or greater should be replaced.
 - The variation of .020 is considered normal.
 - Specific Gravity Readings are as follows:

1.280 and above	=	100% charged cell
1.235 to 1.240	=	75% charged cell
1.190 to 1.195	=	50% charged cell
1.150 to 1.175	=	25% charged cell
1.140 or less	=	0% charged cell
 - Load test the batteries with a battery load tester.
 - The voltage difference should be less than 1 volt, when testing under load. Any battery that has 1 or more volt(s) less than the other should be replaced.

8.4 Battery Charger Error Codes

957745 Chargers Only

Codes that could be displayed on the charger are as follows:

“Bat” = The batteries are not detected. Voltage is below 2 volts,
The polarity could be reversed or batteries disconnected.

“Acd” = the charger programming set for wet lead acid batteries. (not an error)

“Gel” = charger programming set for gel batteries (not an error)

“E01” = maximum battery voltage has been reached.

“E02” = charger is overheating, faulty cooling fan or the cooling air to charger is obstructed.

“E03” = the batteries have exceeded the normal charge time. Possible battery sulfation has occurred. Cycle the batteries several times (charge and discharge).

“Sct” = safety timer operation. This normally occurs after any allotted phase time period has expired.

“Srt” = internal short circuit in charger. Replace the charger.

8.5 Programming the Battery Charger (957760 & 957761 only)



Instructions

1. Remove the rear metal panel on the machine.
2. Remove the 957761 charger completely from the machine.
3. Locate the rubber plug on the bottom right side of the charger.
4. Remove the rubber plug.
5. Locate the selector switch.
6. Use a small flat tip screw driver to turn the red indicator to the desired setting. See the chart below.
7. Replace the rubber plug and install charger into the machine.

Switch Position	Battery Type
1	All Wet Flooded Lead Acid 95 to 115 AH (Group 27)
2	All Wet Flooded Lead Acid 130 to 140 AH (Group 31)
3	GEL/AGM 135 to 155 amp. Hr. (group 31)
4	GEL/AGM 95 to 100 AH and Trojan AGM 102 (AH) hr. (Group 27)

Note: These are the only settings available. For non OEM batteries, please contact supplier for the charging requirements. Select from the list above. The remaining settings do not have any additional functions.



Bottom view with plug



Bottom with plug removed

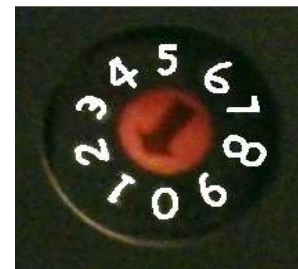

Selector Switch close up

8.6 Battery Charger Error Codes



957760 & 957761 Chargers Only

Faults are displayed red LED on the battery charge indicator.

RED LED BLINKS ONCE AND REPEATS: OUTPUT CONNECTION ERROR.

1. Check for loose or corroded connections between the charger and the batteries.
2. The output may be shorted due to improper connection to the batteries or pinched wires.
3. The output may be connected in reverse polarity to the batteries.
4. The battery voltage may be too high (higher than a 24V battery pack).

This condition can also occur, if the charger is restarted immediately after charging.

Allow batteries to cool down before restarting the charger.

Note: The charger is not damaged by any of these problems except when connected to Batteries totaling 48 volts or more.

RED LED BLINKS TWICE: CHARGER HAS TIMED-OUT

The charging progress timer has elapsed before charging was complete and charger has stopped charging. Possible causes:

1. The batteries are extremely discharged – Unplug the AC cord connection for 30 seconds minimum. Let batteries cool down if hot. Reconnect the AC cord to start a new charge cycle.
2. The electrolyte is low in one or more cells – Correct by adding distilled water.
3. Batteries are weak, old, or have one or more bad cells. Batteries will still charge but capacity will be reduced. Replace the batteries, if needed.
4. If batteries are new, the batteries may need to be conditioned by charging and discharging them. Some batteries may need to be cycled several times in order to condition them to their full potential.

8.6 Battery Charger Fault Codes Cont.



957760 & 957761 Chargers Only

Faults are displayed red LED on the battery charge indicator cont.

All Three lights blink at the same time

1. Charger is restarting
2. Charger is unable to put full output to the batteries
3. Possible loose or poor connections. Check all connections.
4. Batteries may need to be conditioned by charging and discharging them.
Some batteries may need to be cycled several times in order to condition them to their full potential.

8.7 Prime Chargers

- Machines built after serial number 18060266 will be equipped the Prime Chargers
- Prime chargers are pre-programmed at the factory for specific battery types and are not reprogrammable in the field.
- The maximum D.C. output is 12 amps.
- The current (amps) will decrease as voltage climbs.

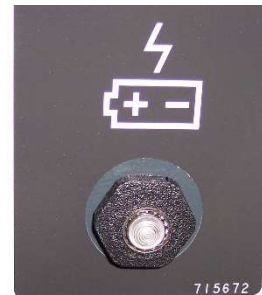

Prime Charger
Indicator Version 1

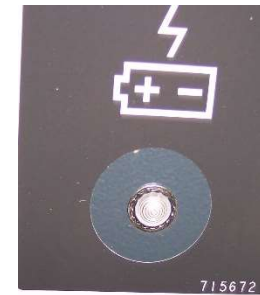

Prime Charger
Indicator Version 2

8.8 Prime Charge Status Indicator

- The charger includes one (1) local LED that can display three (3) colors to indicate charger status and fault information (see Figure 5-1). The functionality of the LED is outlined below. If an optional remote LED is being used, it will provide the same functionality.
- **Amber (Charge Status)** Indicates charge cycle status. See Figure 13-1 for descriptions of the possible states.
- **Green (Charge Status)** Indicates when a charge cycle completes successfully, when an extended Balance/Equalize charge cycle phase is active, or when a post-charge phase is active. See Figure 13-1 for descriptions of the possible states.
- **Red (Fault)** Indicates when a charger or battery fault has occurred. See the FAULTS section.

Amber (Charge Status)	Green (Charge Complete)	Description
Slow Blink	Off	Bulk/Start charge cycle phase (constant power or constant current).
Fast Blink	Off	Absorption/Plateau charge cycle phase (constant voltage). Greater than 80% charged.
Solid On	Off	Finish charge cycle phase (constant current). Not all charge profiles include a Finish phase.
Off	Fast Blink	Balance/Equalize phase. An extended charge cycle is occurring because a trigger condition has been met (cycle count, etc). Not all charge profiles include a Balance/Equalize phase.
Off	Solid On	Charge cycle complete.
Off	Slow Blink	Charge cycle complete. Post Charge phase (constant voltage float, etc). Not all charge profiles include a Post Charge phase.

8.9 Prime Charger Indicator

(Fault Codes)



Removing AC power from the charger always clears a fault.

If the charger was factory-configured for off-board use, disconnecting the charger from the battery pack also clears a fault.

If a fault cannot be cleared after taking appropriate corrective action, contact your dealer for troubleshooting and/or service.

	Red LED	Green LED	Amber LED	Description
Charger	Slow blink			AC voltage low fault - Slow blink Red LED
	Slow blink	Slow blink		Over temperature fault - Alternate between slow blink red and slow blink green
	Slow blink		Slow blink	Charger issue (not outputting current, relay didn't pull in, EEPROM error, internal supplies out of range, etc.) - Alternate between slow blink red and slow blink amber
Battery	Fast blink			Battery not present in On-board mode only (Ob=1) - Fast blink red only
	Fast blink	Fast blink		Under voltage fault - Alternated between fast blink red and fast blink green
	Fast blink	Slow blink		Over voltage fault - Alternated between fast blink red and slow blink green
	Fast blink		Fast blink	Overall charge maximum time - Alternated between fast blink red and fast blink amber
	Fast blink		Slow blink	Phase maximum time - Alternated between fast blink red and slow blink amber
Vehicle	Solid			Temperature probe or lockout error - Solid on red

8.10 IEB Filon Charger

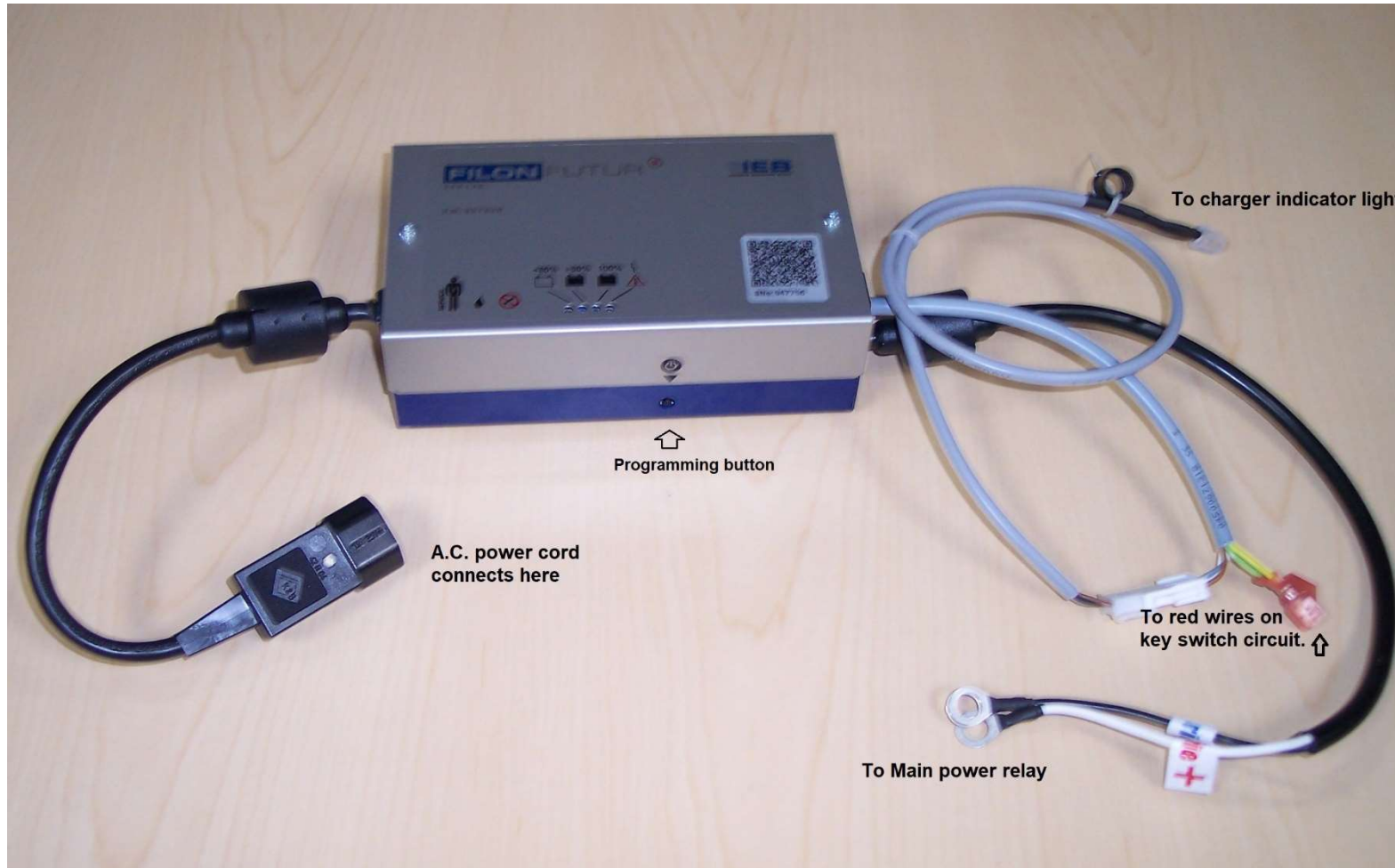

8.11 IEB Charger Status Indicator



1. General

Up to eight charging characteristics are programmed in the charger. A switch is used to select a characteristic. LEDs display the selected characteristic(s).





2. LED Display

The different information supplied by the display is described below.

Charging mode:

Charging Mode	LED Display		
			
Primary charging	X		
Secondary charging		X	
Charging end / charge maintenance			X

Error messages:

Error Message	LED Display			
				
Battery is missing	X			
Time error		X		
Hardware error			X	
Temperature error				X

8.12 IEB Charger - Charging Profiles



The IEB chargers have 3 different programming options. The LEDs lighted on the charger, during programming mode are shown below for each charging profile.

- Program **0** is for most AGM, maintenance free, 102 to 135 amp hour, group 27-31 batteries.
- Program **2** is for wet/flooded, 155 to 193 amp hour, group 31 batteries.
- Program **3** is for wet/flooded, 115 to 143 amp hour, group 27 batteries.
- Programs **1, 4 to 7**, have no additional functions.

Charging Characteristics Program (flashing LEDs)	LED Display							
Program 0	X							
Program 1		X						
Program 2			X					
Program 3				X				
Program 4					X			
Program 5						X		
Program 6							X	
Program 7								X

8.13 IEB Charger – Programming

The programming button switch is located on the side of the charger. (Shown on right)

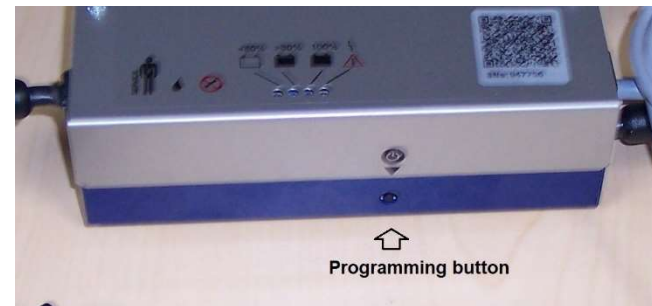

The switch has different functions depending on the operating status of the charger.

- Switching charger ON/OFF.
- Setting pause mode.
- Program selection mode. - Checking / setting the charging characteristics.

a) Charger is switched on

Switch < 1 sec	PAUSE mode on/off. Charging is stopped/continued. The green 100% LED and the yellow <80% LED flash alternately. (Pause mode is autom. deactivated after 1 minute.)
Switch ≥ 2 secs	Charger switches off. Display goes out. (Condition for charging characteristic setting.)

8.13 IEB Charger – Programming Cont. **Minuteman**[®] *Excellence Meets Clean*

b) Charger is switched off

The charger automatically starts again after 15 seconds.

Switch < 1 sec	Charger switches on.
Switch > 10 secs	Program selection mode on. The current setting is displayed. Display flashes 4x per second.

c) Program selection mode is enabled (selection of the charging characteristics)

The program selection mode is cancelled automatically 1 minute after the last switch use. If a new setting has not been confirmed, the original setting is kept.

Switch < 1 sec	The next respective program is displayed. If the displayed charging characteristic is the current setting, the display flashes faster (1x → 4x/second).
Switch > 5 secs	The displayed program is applied as the new setting. The display flashes faster (4x/second).
Switch 2 to 4 secs	Exit program selection mode. Charger switches off.

9. Battery and Error Code Indicator

Traction Drive Models only

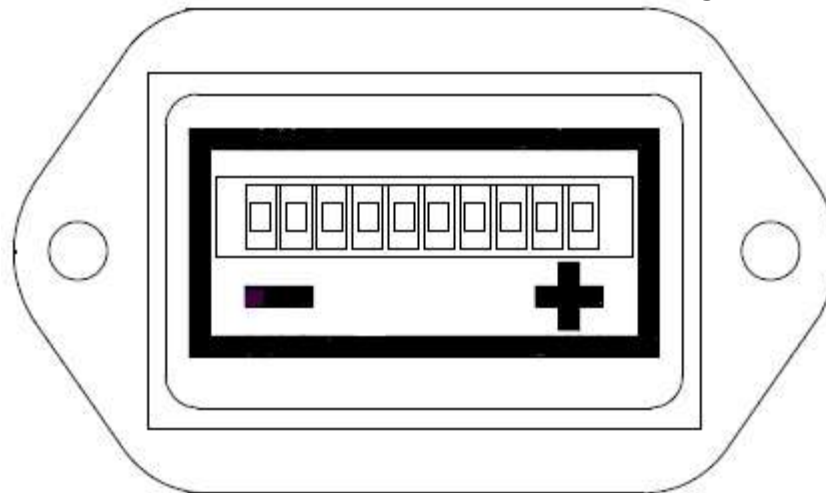

- The indicator will display the charge status during machines operation. The indicator uses ten LEDs. 1 to 10 LEDs may be illuminated at any given time. 10 being a fully charged battery pack. 1 LED would be a discharged battery pack.
- The indicator will also will display errors by rapidly flashing 1 to 10 LEDs. See the following references for the type of error that it has detected.

9.1 E17TD & E20TD Error Codes

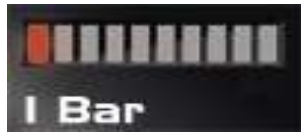

1 Bar = Low Battery Voltage

The battery needs charging or there is a bad connection to the battery. Check the connections to the battery. If the connections are good, try charging the battery.



2 Bars = Traction Motor Disconnected

There is a bad connection to the Traction motor. Check all connections between the motor and the control system.



3 Bars = Traction Drive Motor Shorted

There is a short in the Traction Drive circuit. Possible short in the drive motor or harness.

9.1 E17TD & E20TD Error Codes



4 Bars = Battery Lockout

The traction drive controller has shut down because of low battery voltage. Charge the batteries. If problem still exists: Test batteries and check all battery connections.



5 Bars = Not Used



6 Bars = Not Used

9.1 E17TD & E20TD Error Codes



7 Bars = Throttle Trip

A throttle trip is indicated. The potentiometer is not detected in circuit or incorrect resistance value seen by I-drive controller. Test the 5K potentiometer circuit.



8 Bars = Control System Trip

A control system trip is indicated. Make sure that all connections are secure. This can also occur if the key switch is turned on and off rapidly



9 Bars = Not Used

9.1 E17TD & E20TD Error Codes



10 Bars = High Battery Voltage

An excessive voltage has been applied to the control system connections. This is usually caused by a poor battery connection. Check the battery connections.



No Bars = Control System in Sleep Mode

The control system has entered sleep mode. Switch the control system off and then on again.

9.1 E17TD & E20TD Error Codes



Start UP

This is an initialization message. Repeats until system is verified to be functional. Occurs during the initial startup of the machine, if it hasn't been powered up for a period of time. Note: This is not a fault or error.

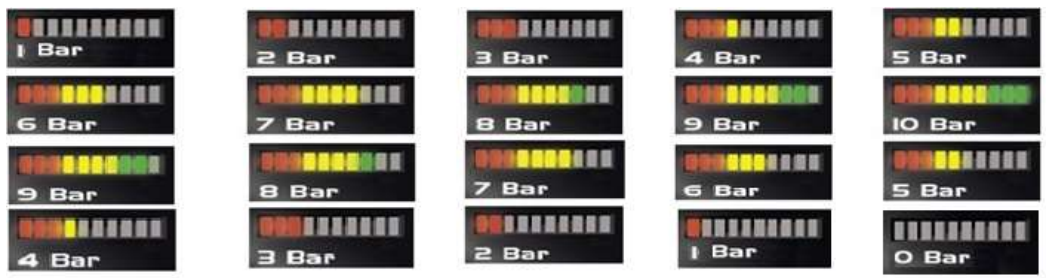

Ripple = Throttle Displaced

Looks similar to the start up above. Repeats. The drive switch has been activated while powering up the machine. Place the throttle in the neutral position and turn the control system on and off again. Possibly the drive switch is stuck on.

10 Trouble Shooting Brush Motor Circuit - (all models)

Brush motor does not work in scrub mode. (Brush unload feature works)

1. Test the unload function by turning power switch key counter clockwise with brush in the up position. Brush should start and stop abruptly when releasing the key.
2. If brush motor runs in the unload function, but does not stop abruptly
3. Test the switch located next to the brush lift pedal (Fig 1) 1 switch for unload and 1 solution switch (if equipped)
4. Test brush switch located in drive handle below (Fig 2) Note BD models has 1 switch in handle. The TD version has 2 switches, one for the drive and the other for the brush motor.
5. Test Brush switch located behind the brush motor. (Fig.3)

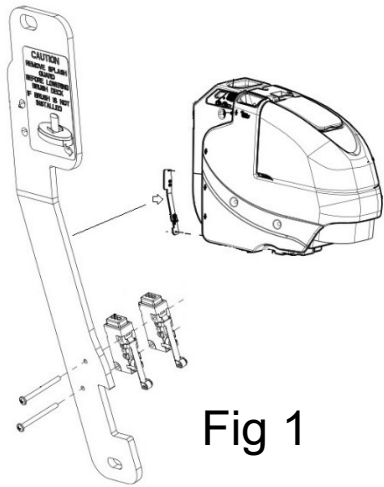

Fig 1

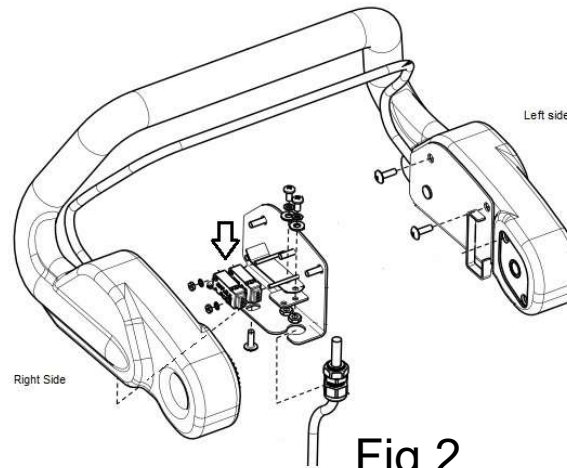

Fig 2

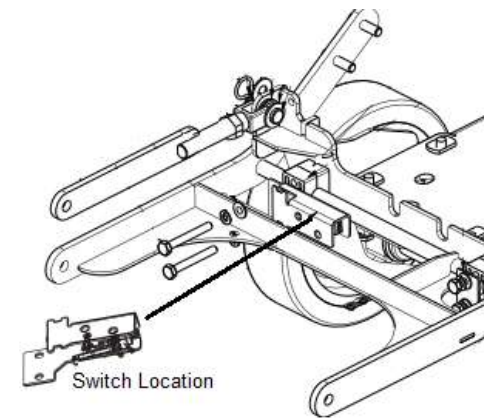
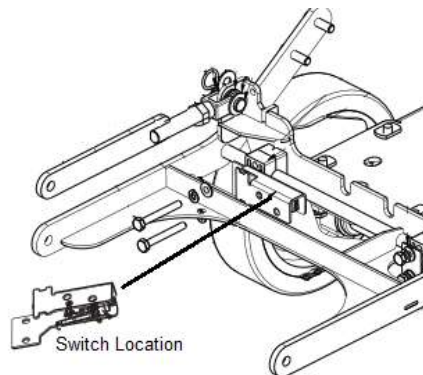

Fig 3

10.1 Trouble Shooting Brush Motor Controller (Sport Models only)

1. The I-drive brush motor controller works similar to the traction drive I-Drive controllers, except for is rated for 180 amps.
2. The sport key switch changes the speed of the brush motor speed from 200 rpms to 400 rpms.
3. The potentiometer for the brush controller is mounted inside the electrical box and is always set to the full clockwise position. Turning it counter clockwise will slow both speeds of the brush motor. Turning it full counter clockwise will shut the brush motor off.
4. When brush motor current reaches 50 to 52 amps, the motor will be throttled back to 35 amps to prevent from over heating over loading. Try dispensing more water and reduce pad pressure by removing the weighted plate, if needed to prevent controller from over heating and shutting down. (circuit breaker has not tripped)
5. The brush controller has a thermo shut off built in it, and it will shut down the brush motor when the controller overheats. It will rest automatically.
6. The brush motor can be activated in both the unload and scrubbing modes.
7. When using the unload feature the key switch must be held in the counter-clockwise position for at least 5 seconds so that the controller has time to boot up.
8. Testing Potentiometer - See page 59.
9. If the unload feature works, but the brush motor will not run in the scrubbing mode. Check the brush switch in the handle and the switch in the front of the machine. See below



11. Squeegee (Curved)

11.

Rear Squeegee

- A Squeegee
- B Star-shaped knob
- C Adjusting screw for angle adjustment
- D Suction hose
- E Blade fastening device
- F Washers for caster height adjustment

Cleaning the Squeegee

Check the squeegee (A) daily and clean as necessary.

1. Pull off the suction hose (D).
2. Loosen the two star-shaped knobs (B).
3. Remove the squeegee (A).

Changing the Squeegee Blades

Check the inner and outer squeegee blades on the squeegee (A) weekly for signs of wear. The squeegee blades can be reused by turning them.

1. Pull off the suction hose (D), loosen the two star-shaped knobs (B) and remove the squeegee.
2. Unlock the fastening device (E) and remove the outer squeegee blade. Turn the squeegee blade or install a new one, as necessary. Change the inner squeegee blade in the same way.

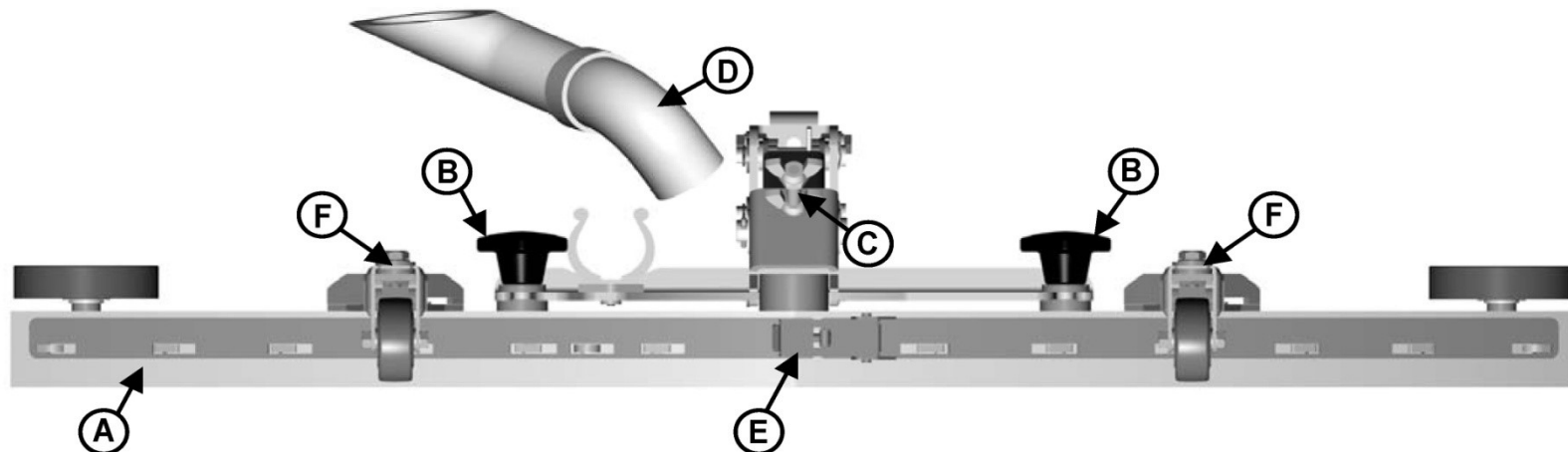

11.1 Squeegee (Curved)

11.1

Adjusting the Squeegee Blades Angle Adjustment

The angle adjustment is the decisive factor in ensuring that the squeegee blades on the squeegee lie evenly on the floor.

1. Park the machine on a level surface and lower the squeegee.
2. Loosen the lower wing nut (B) on the adjusting screw (C) and adjust the squeegee using the adjusting screw so that the ends of the squeegee blades still have contact with the floor. By turning the adjusting screw (C) counterclockwise, the clearance between squeegee blade and floor is **reduced** in the center (Fig. 1). When turning the adjusting screw (C) clockwise, the clearance between squeegee blade and floor is **increased** in the center (Fig. 2).
3. Switch the machine on and check the suction pattern. When the machine is in operation, the entire surface of the squeegee blades (center and outer areas) must be applied as evenly as possible.
4. Tighten the lower wing nut (B) on the adjusting screw (C) against the metal bracket to lock in the pitch setting.

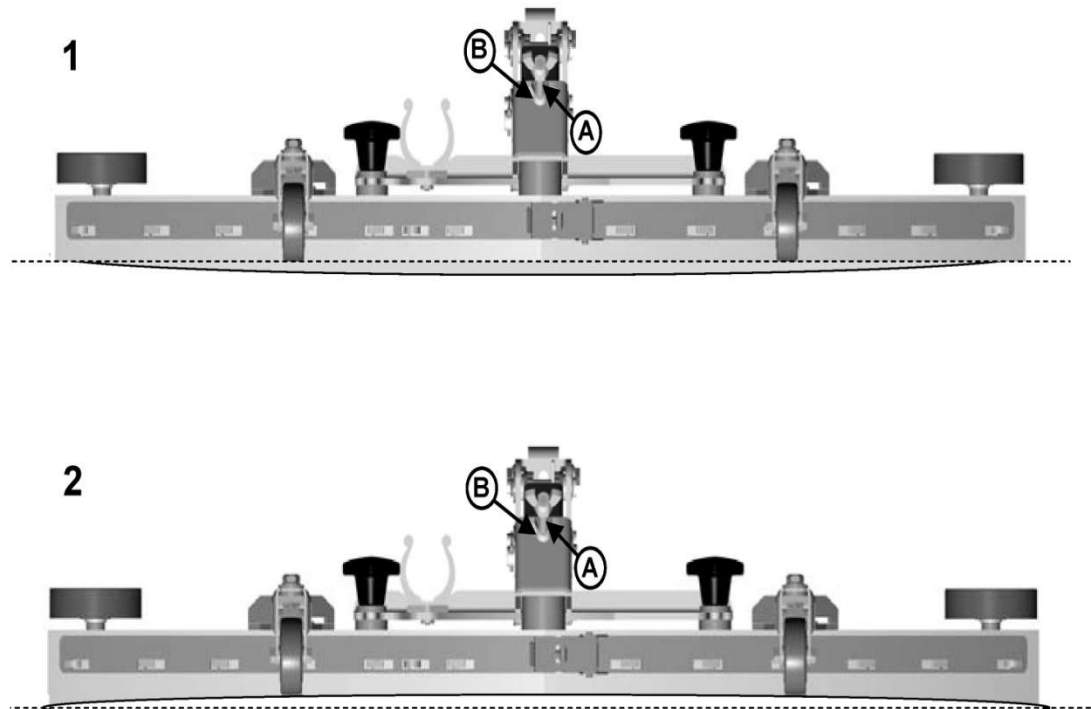

11.2 Squeegee Caster Adjustment (Curved)

11.2 Clearance between support roller and floor with unfolded sealing strip (Factory presetting): 3 mm \pm 0.5 (Fig. 5/2).

Place additional 1mm spacers (pos. 15, Fig. 5/3) between the angle and the fixed roller housing (pos. 7, Fig. 5/3) to increase clearance or remove existing 1mm spacer from between the angle and the fixed roller housing in order to reduce the clearance. Re-insert the spacers removed from between the angle and the fixed roller housing again above the fixed roller housing to allow complete tightening of the screws.

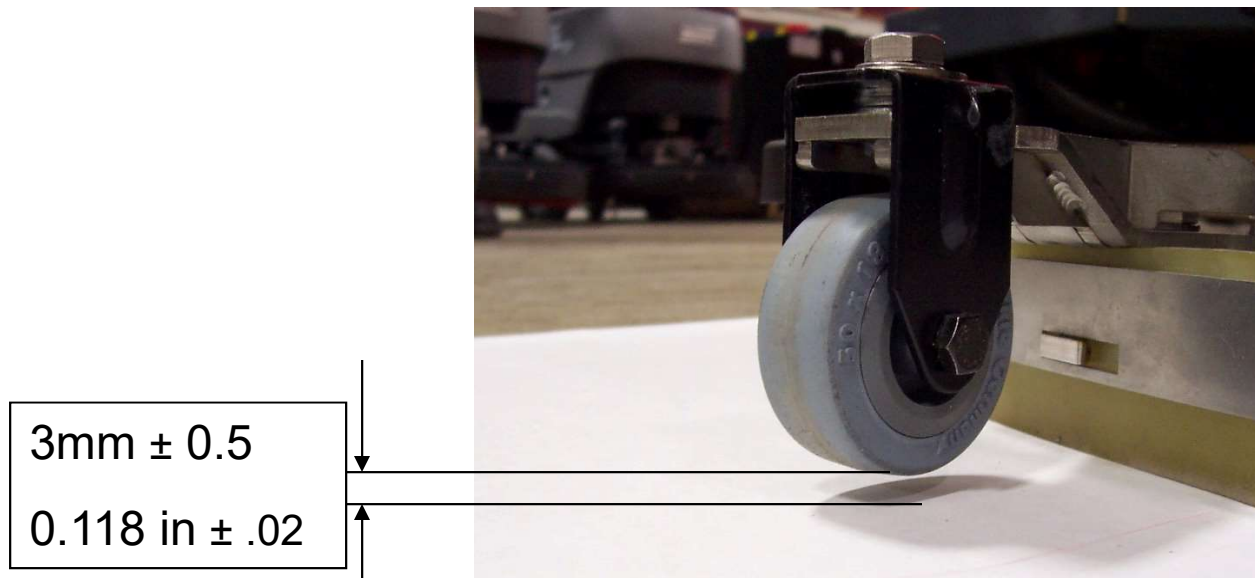

11.2 Squeegee Caster Adjustment (Curved)

11.3 Curved Squeegees Only

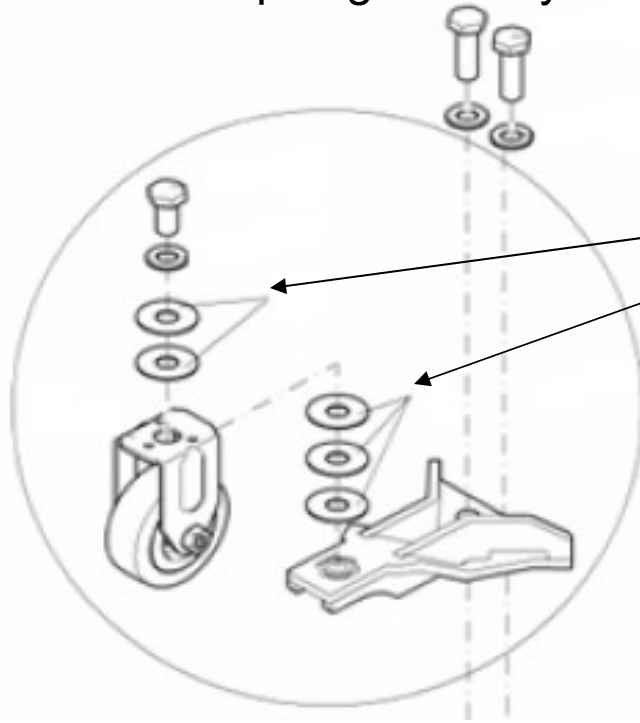

Washers may be rearranged to change the height of the squeegee caster.

Note: When adjusting the wheel height, there should always be 5 washers on each wheel assembly in order fully tighten bolts. Move washers from the top to the bottom of the bracket or visa versa when making adjustments. See following page.

11. Squeegee Caster Adjustment (Curved)

11.4 Curved Squeegees Only

•Possible squeegee caster washer combinations.

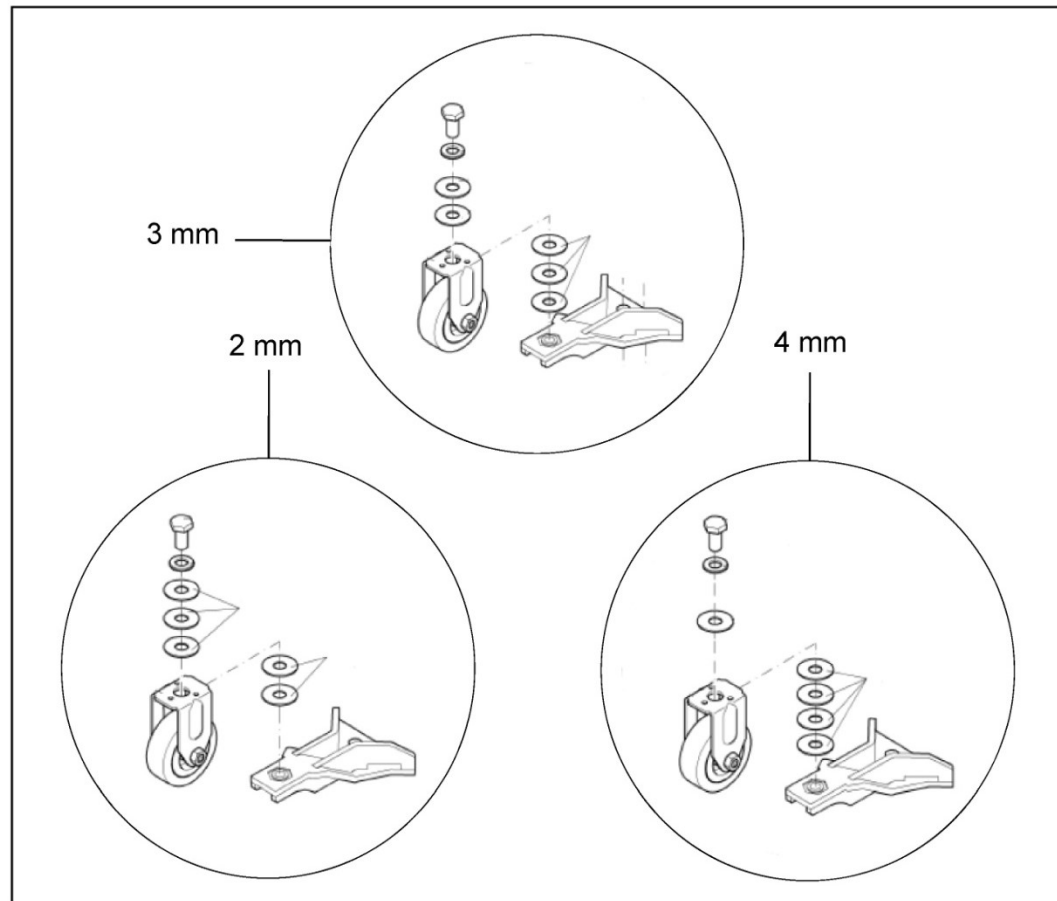

12. Maintaining Wet Batteries

1. **Always keep the water levels above the plates**
2. **Fill the batteries with distilled water only. Tap water can cause an excessive build up of minerals and reduce the chemical reaction of the batteries. This will shortening the life and performance of the batteries.**
3. **Use appropriate filling devices when filling the batteries. Do not use a garden hose or metal containers. Flooding the batteries can flush the electrolyte out of the battery and shorten its life.**
4. **Fill cells 3/8 to 1/2 of an inch above the separators. Do not fill above the fill marker of the batteries. Over filling can cause the electrolyte to percolate out onto the case while charging.**

12. Maintaining Wet Batteries

5. Check water level daily. Fill, if needed.
6. Keep all the battery cable connections tight.
7. Keep all the battery posts and cables clean. Clean the battery cases with a mixture of baking soda and water solution or commercial spray that neutralizes the acid. Spray the cases with a water displacement chemical or a silicone. This will help break the flow of current across the case and increases the life of the battery.

Note: The electrolyte on the surface of the case can cause:

- A. The batteries to discharge faster even while sitting and have a shorter run time.
- B. The battery charger to stay on for extended periods. Thus causing an over charge condition and shortening the life of the batteries.

13. Load Testing The Batteries

- **Load test battery with an automotive type load tester. This test puts an ampere load on the batteries and measures the voltage at the same time.**
- **If voltage drops too low on the meter, this would indicate that the batteries are weak or discharged.**
- **A fully charged good battery should test in the good or green range of the meter. Load testing can identify dead cells, broken or disconnected plates, weak cells and charge status.**
- **This is good test, however it can only detect these types of failures.**
- **Most load testers require putting a load on the batteries for 10 seconds.**
- **Load testing may not detect all short run time issues.**

14. Hydrometer Testing Batteries

- Hydrometer testing can be used to measure the specific gravity of deep cycle batteries. This allows you to detect weak cells, which are causing loss of running time. It can only detect this type of problem. The hydrometer should have specific gravity markings such as 1.265, 1.250, 1.225, and so on.
- Hydrometers with the four balls are not accurate enough for this test and are not recommended.
- Fully charged batteries should read 1.265 and will decrease as batteries are discharged until they reach 1.120. This test should be done when batteries are charged and cooled. Allow one hour or more to cool. It can also be done after batteries are partially discharged, if they are allowed to cool. However, you will not be able to detect the full capacity of the battery.
- Note:** Maintenance Free batteries can not be tested with a hydrometer. Do not attempt to remove caps or covers. This will destroy the battery.

14. Hydrometer Testing The Batteries

•Hydrometer Testing

- To do an accurate test, the battery water level must be high enough to extract enough electrolyte to fill hydrometer so that the float floats. Water should be added prior to charging in order for let the electrolyte to mix.
- The greater the variation between cells readings, the greater the loss of run time. For example, if the readings are 1.265, 1.265 and 1.225 in one 6 volt battery. The low cell would be considered weak and greatly reduce the performance of the battery or shorter run time. This battery would have a point 40 variation. Batteries that have weakened cells in most cases it can still be used as long they continue provide adequate run time. A battery with a point 40 variation or more should be determined defective.

14. Hydrometer Testing The Batteries



- **Minuteman batteries are rated for about 500 charge cycles. The life of the battery will be greatly dependent by the maintenance they receive.**
- **Every time the batteries are charged it uses one cycle.**

- **The specific gravity will reflect the percentage of charge remaining in the battery.**
- **100% charge = 1.265 or higher Specific Gravity**
- **75 % charge = 1.225 Specific Gravity**
- **50 % charge = 1.190 Specific Gravity**
- **25 % charge = 1.120 Specific Gravity**

- **Note : AGM & Gel maintenance free batteries can not be tested with the hydrometer. Do not attempt to open cell covers or caps.**
- **Doing so will destroy the battery.**

15. Transporting The Machine

When transporting the machines on a trailer or truck always:

- **Tie down the machine securely.**
- **Lower the brush head assembly completely to the floor.**
- **Turn the machine off.**
- **Failure to do the above may result in damage to the machine.**

16. Key Switch

- The key switch has 8 terminals. Below shows the three different switch functions. The black bars indicate the internal connection made by the switch in each position.

Switch Off

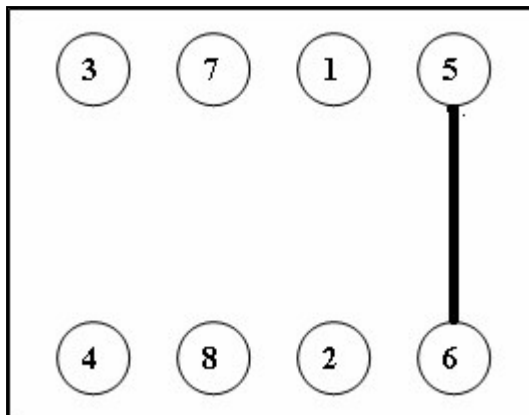

Switch On

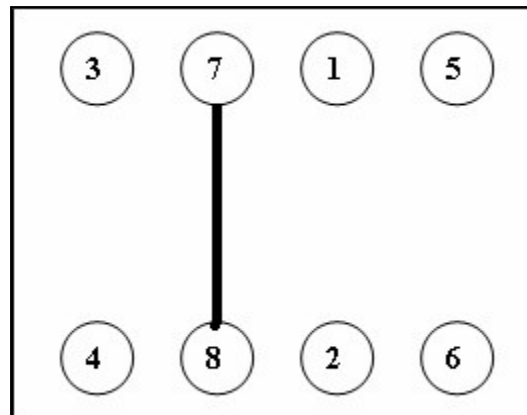

Switch Unload

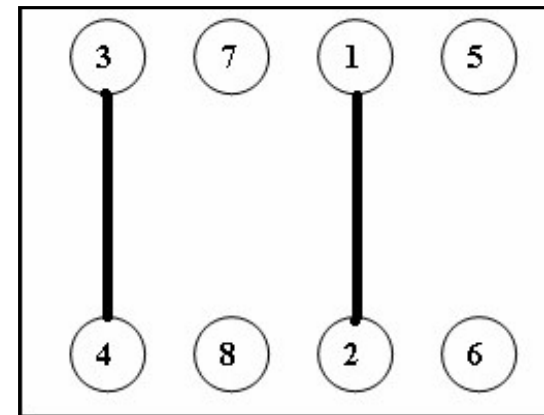

17. Solution Filter (Version 1)

17.

In-Line Solution Filter Assembly

The solution solenoid, which shuts off solution flow when the bail handle is released, is protected from debris by the in-line filter assembly. The filter assembly is located at the rear of the machine on the left hand side, just under the solution tank. It is important to check and clean the screened washer inside the assembly regularly to ensure proper solution flow. To open, unscrew the assembly (Note that the cone of the washer is facing out toward the rear of the machine). Remove washer and rinse, reinsert and screw assembly together, tightening by hand. **Overtightening with tools may damage the plastic threads.**

- A Fitting, MGHT
- B Screened Washer
- C Hose Barb Insert
- D Fitting, FGHT

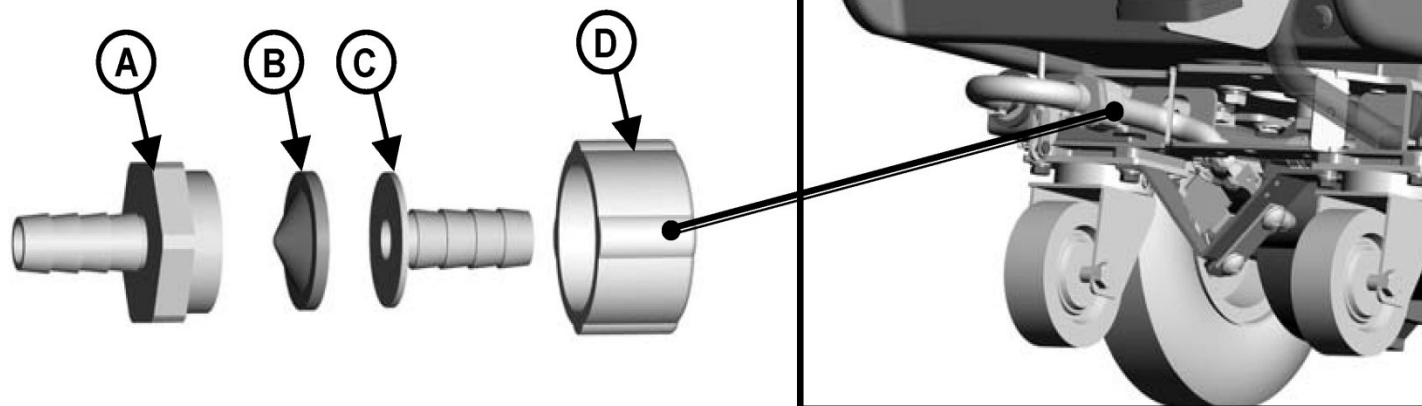

17.2 Solution Filter (Version 2)

1. The solution filter is located under the machine.
2. The filter can be cleaned by unscrewing cap.
3. Drain solution tank before cleaning filter.

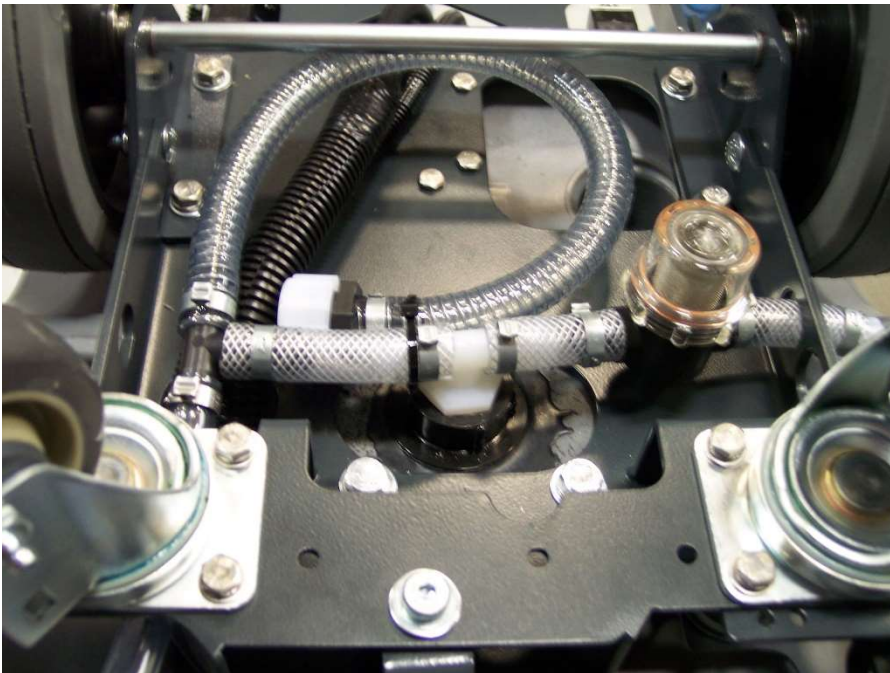

Filter Location

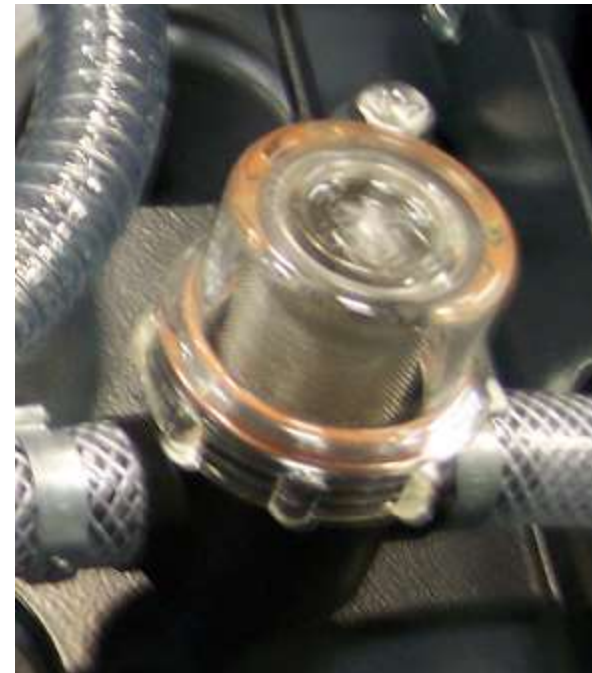

New Style Solution Filter

18. Testing the Main Power Relay on the E17, E20 and E26ECO

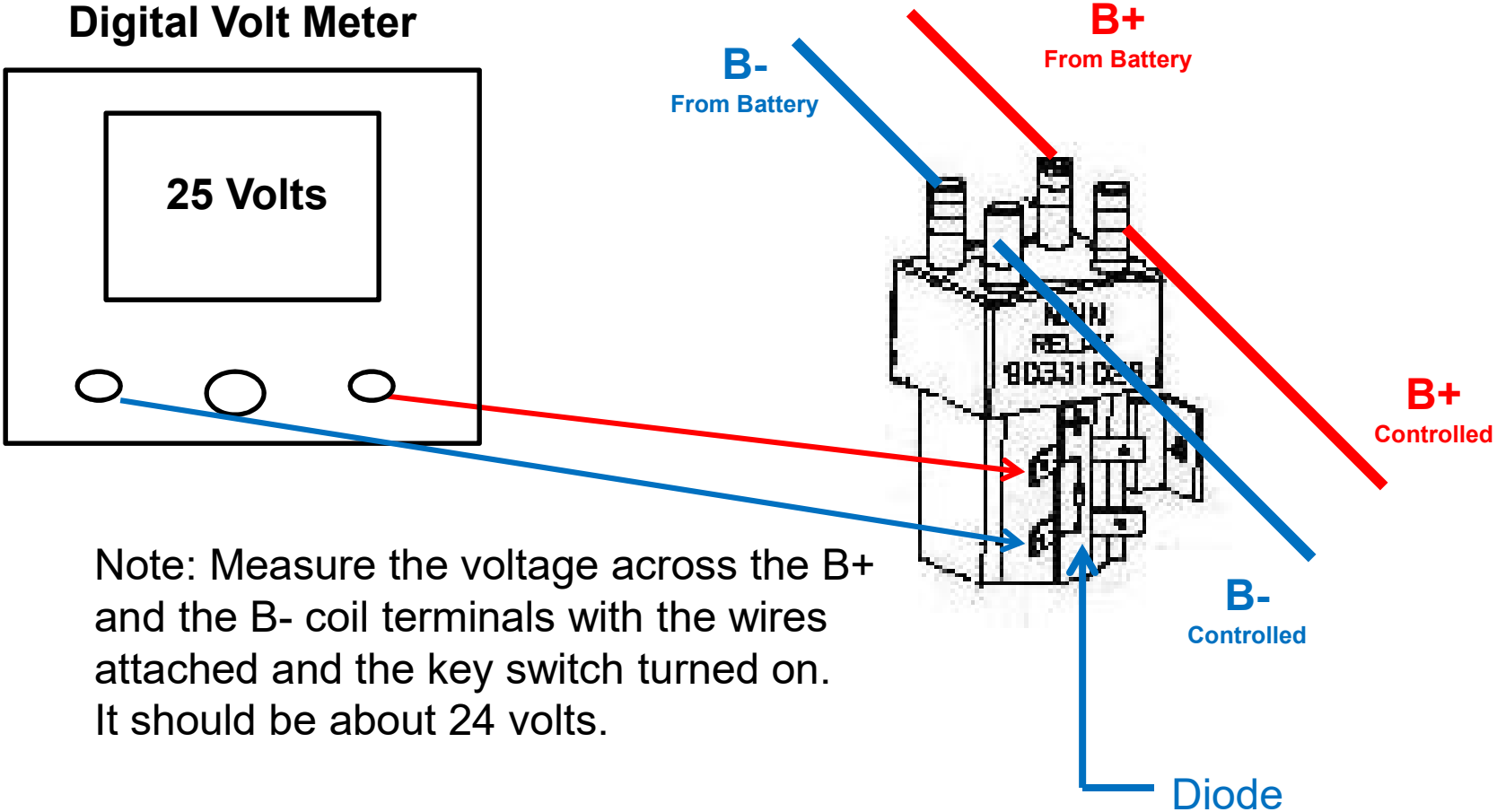

Note: Measure the voltage across the B+ and the B- coil terminals with the wires attached and the key switch turned on. It should be about 24 volts.

18. Testing the Main Power Relay on the E17, E20 and E26ECO

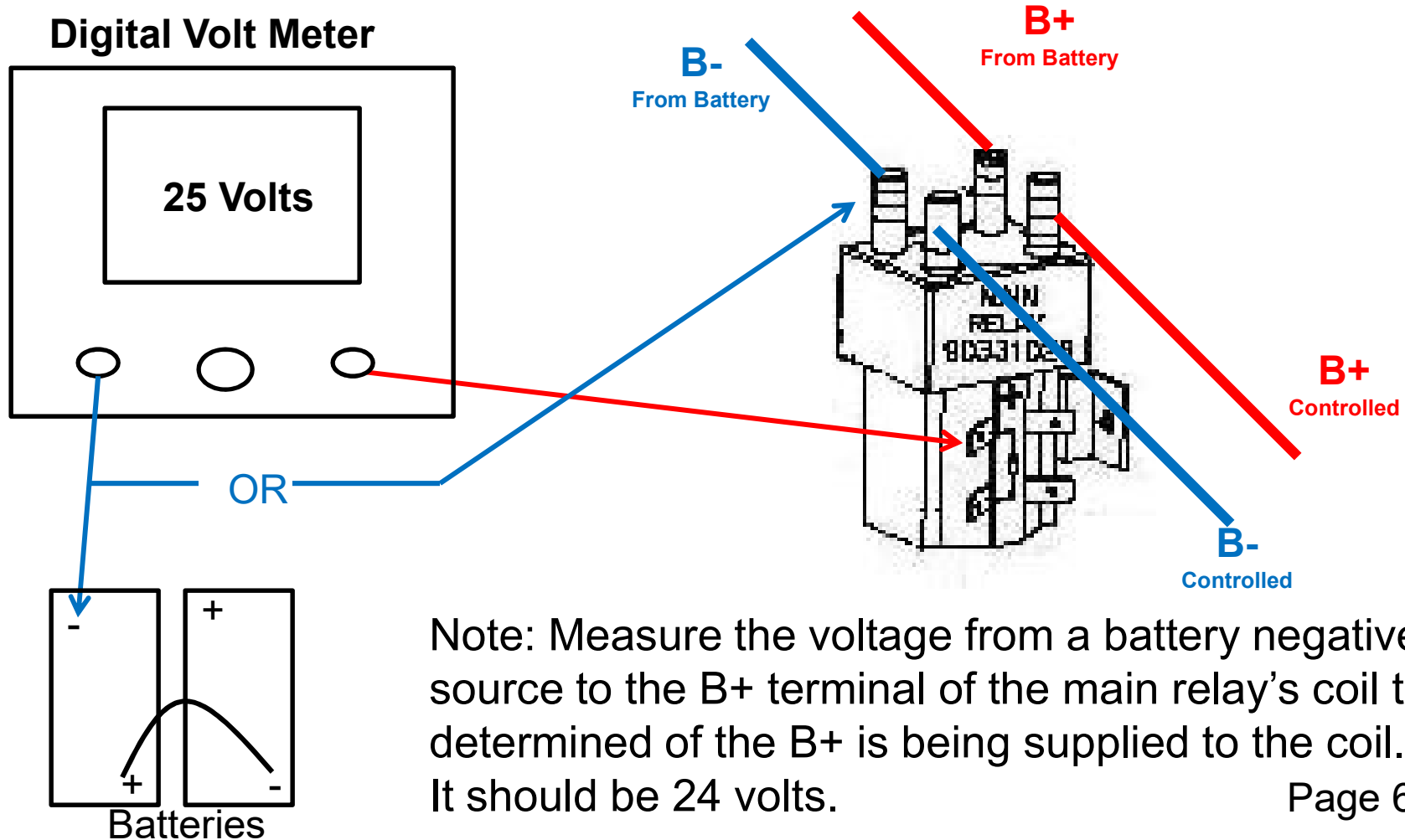

18. Testing the Main Power Relay on the E17, E20 and E26ECO

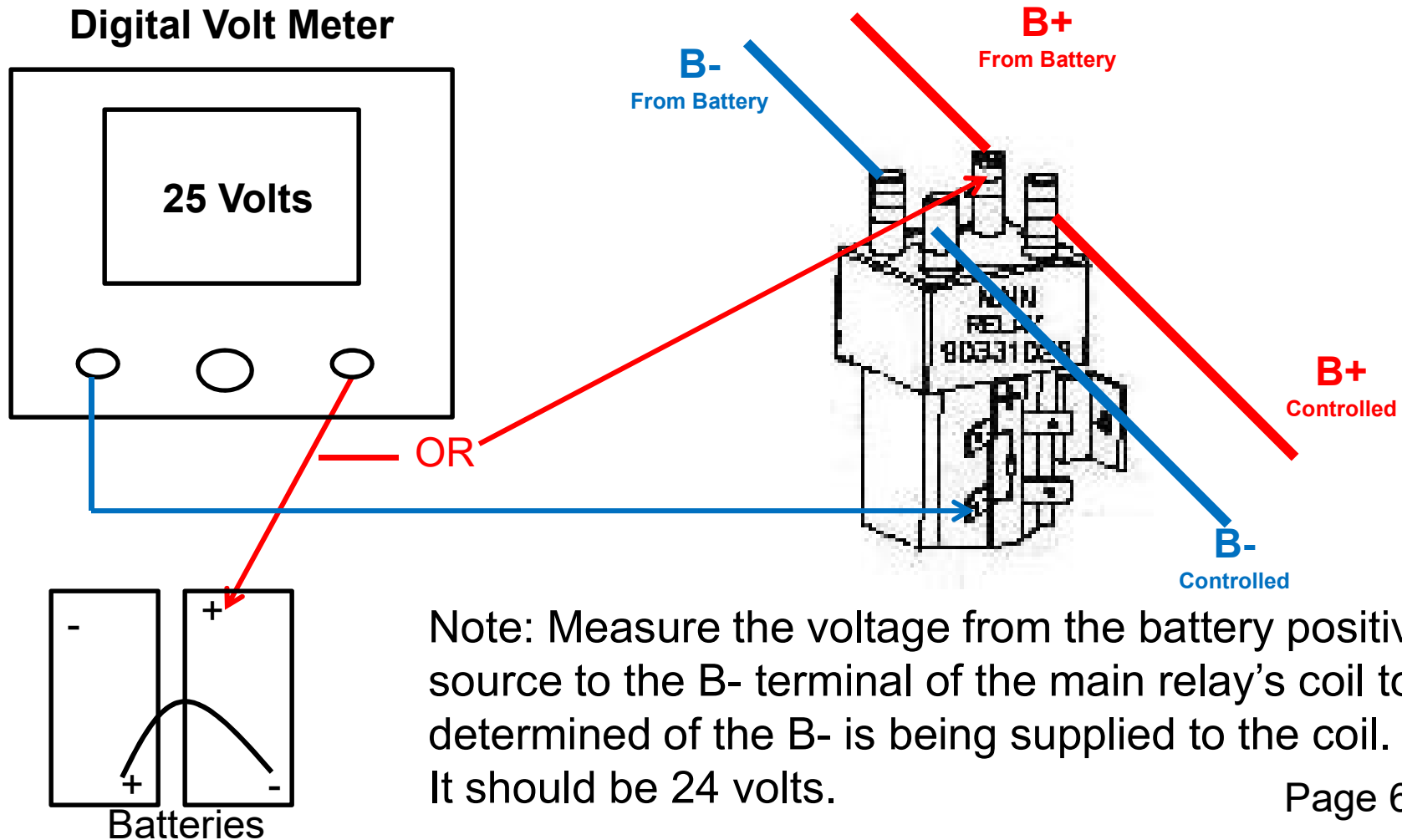

18. Testing the Main Power Relay on the E17, E20 and E26ECO



Note: Measure the voltage across the battery side across the B+ & B- terminals when the machine is under load.

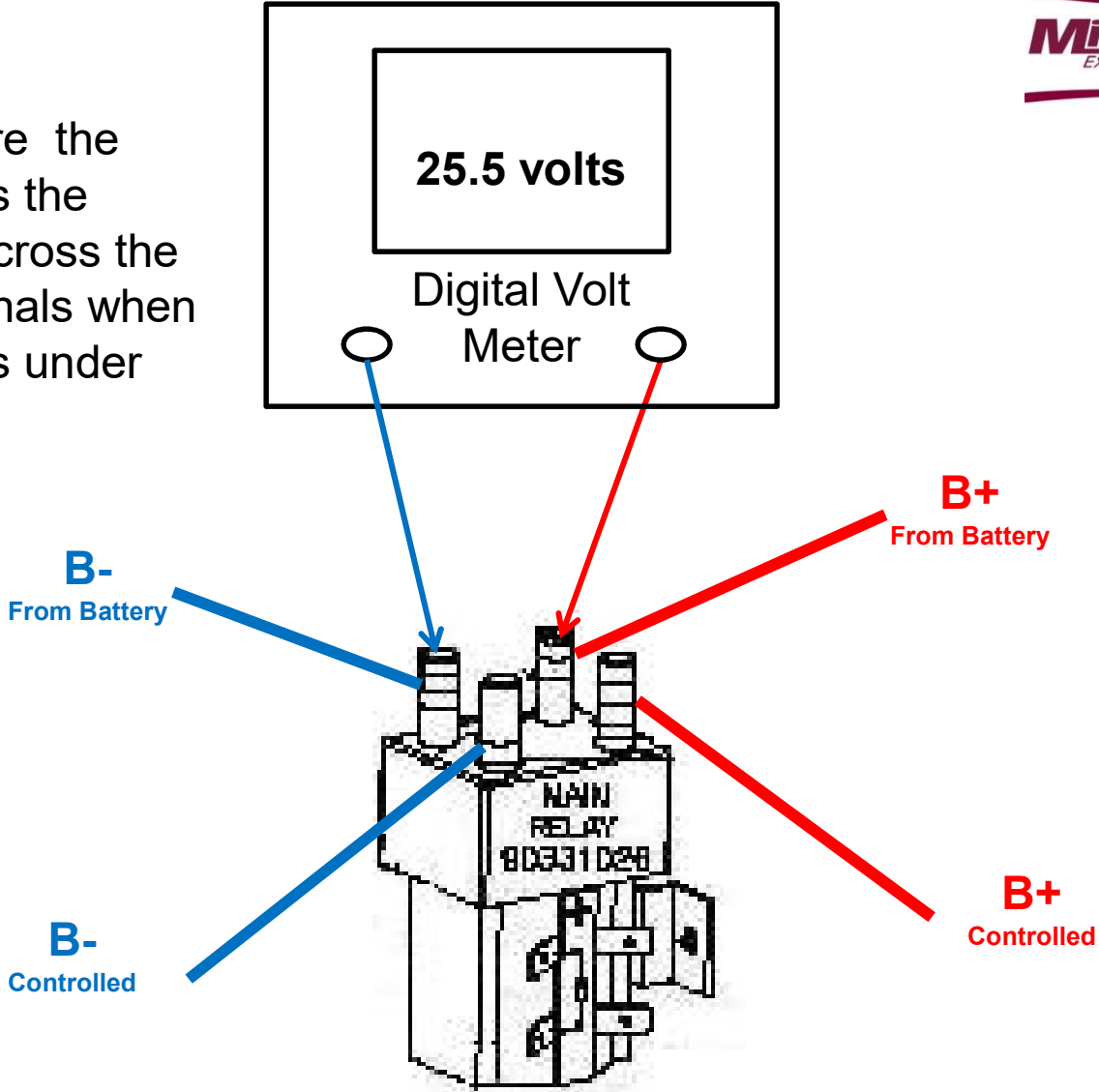

18. Testing the Main Power Relay on the E17, E20 and E26ECO



Note: The voltage should be exactly the same as incoming battery side when the machine turned on and is under load (motors are running).

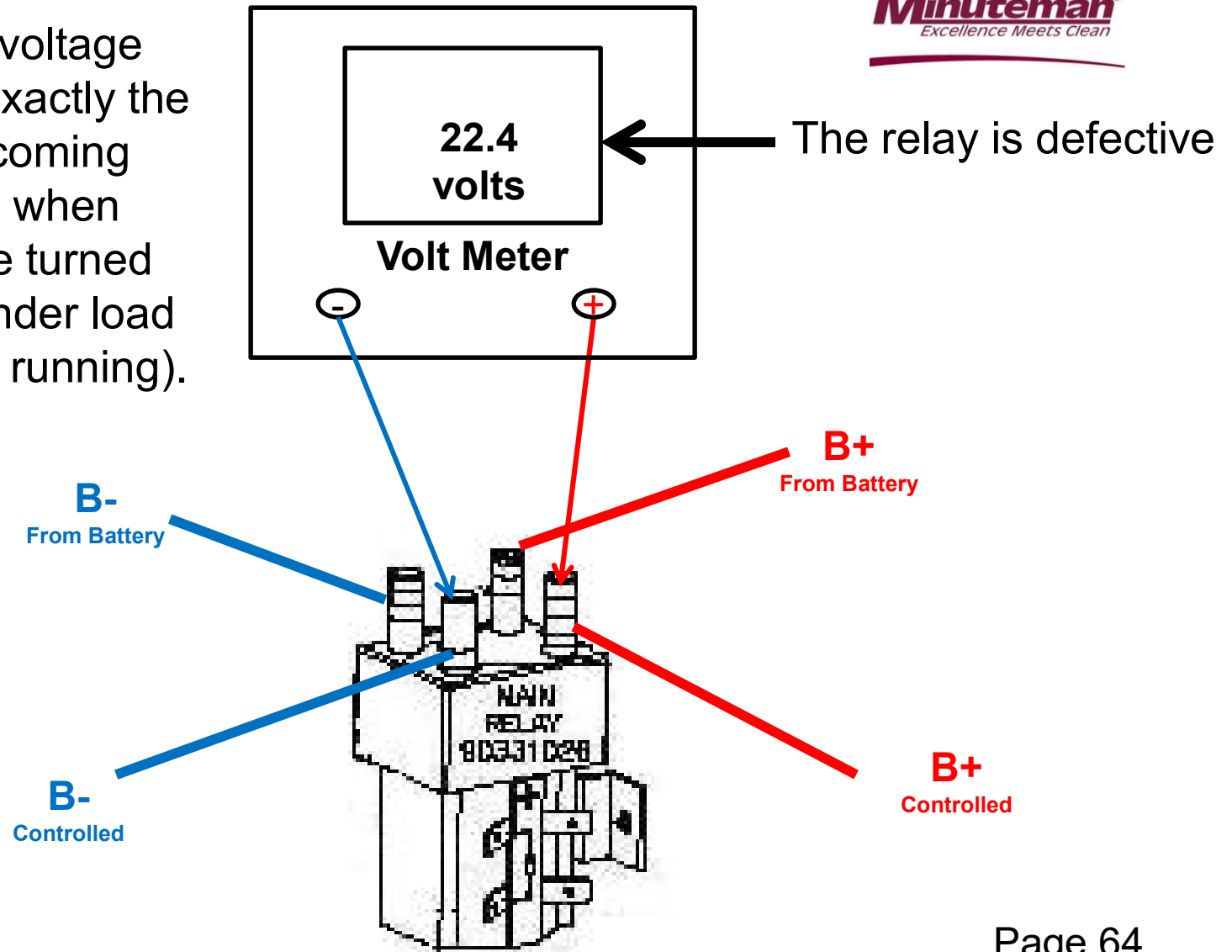

19. Trouble Shooting the Drive Circuit

Testing the Potentiometer and Drive Switch circuit.

The potentiometer, drive switch and forward switch circuit can be tested all together from the 14 pin harness connector at the I-Drive controller (traction drive models only).

- Remove the rear panel of the machine.
- Locate the I-Drive controller (silver box)
- Disconnect the 14 pin electrical connector on the I-Drive
- Use an ohm meter (analog for best results) and measure the resistance between the black/orange and black/white wires. It should be approximately 5K (4.7) ohms. If not see "Testing the Potentiometer".
- Test the resistance between the black/pink and black/orange wires. Turn the shaft of the potentiometer while measuring. The forward and reverse switch will need to be in the forward or reverse position (test in both positions). Activate the drive lever. The resistance should vary from 5K to Inf. The resistance should change smoothly, If not see "Testing the Potentiometer".

Testing the Potentiometer

- Disconnect the potentiometer from the circuit.
- With a ohm meter, measure the resistance across the black/orange wire and the black/white wire. The resistance should be 5K (about 4.7 K ohms). If not replace potentiometer.
- Test the resistance between the black/pink and the black/white wire. (Use an analog meter for best results) Turn the shaft of the potentiometer while measuring. The resistance should vary from 5K to Inf. The resistance should change smoothly, if not replace the potentiometer.
- Test the resistance between the black/pink and the black/orange wire the wire. Turn the shaft of the potentiometer while measuring. The resistance should vary from 5K to 0 (zero). The resistance should change smoothly, if not replace the potentiometer.

19.1 Trouble Shooting - Traction Drive Switch



Testing the Drive Switch.

- Remove the access plate on the right side of the drive handle. Test the switch that is connected to the red and white wires coming from the main harness. The blue and black connection should test open until the switch is activated. It should close when it is activated. If it doesn't replace the switch.

19.2 Trouble Shooting –Vacuum Motor

The vacuum motor will not turn on Traction Drive models only.

1. Verify the vacuum switch is functioning correctly. The machine should not move in reverse with the squeegee (vacuum on) in the down position. When squeegee is raised, the machine should back up.
2. Remove the rear panel of the machine.
3. Measure the voltage across the coil (small) terminals of the vacuum contactor (do not go to the battery for this test.) with squeegee/vacuum switch activated and driving the machine forward.
4. The wires will need to be connected to terminal while doing test.
Note: Lift the drive wheels off the floor before doing test.
The voltage should be 20 to 24 volts. If not go to step 5.
If the 20 to 24 volts is present, test vacuum relay step # 8.
5. Remove the diode from the contactor and test with a multi-meter.
It should have continuity in one direction. Replace, if it shorted in both directions.
Note: The diode should be wired with the silver band closest to the red (positive) terminal when it is mounted to the relay terminals.



19.3 Trouble Shooting – Vacuum Relay

6. Retest for voltage across the vacuum coil (small) terminals with the squeegee switch and drive activated. If the voltage is below the 18 volts, replace the I-drive controller. If voltage is above, continue testing the vacuum relay in step 7.

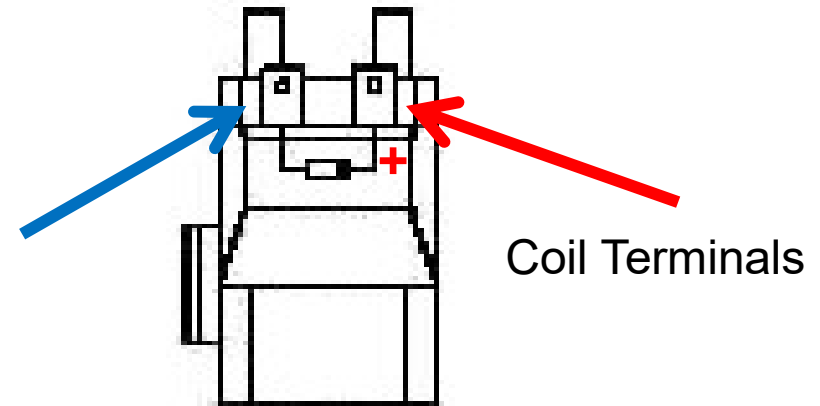

-
7. Testing the vacuum motor relay (all models)
 1. Power up the machine.
 2. With the vacuum switch and drive circuit activated.
 3. Test for voltage across the two large contact terminals on the vacuum relay. It should read 0 (zero) volts. When it is deactivated it should measure 24+ volts.
 4. If not replace the relay.

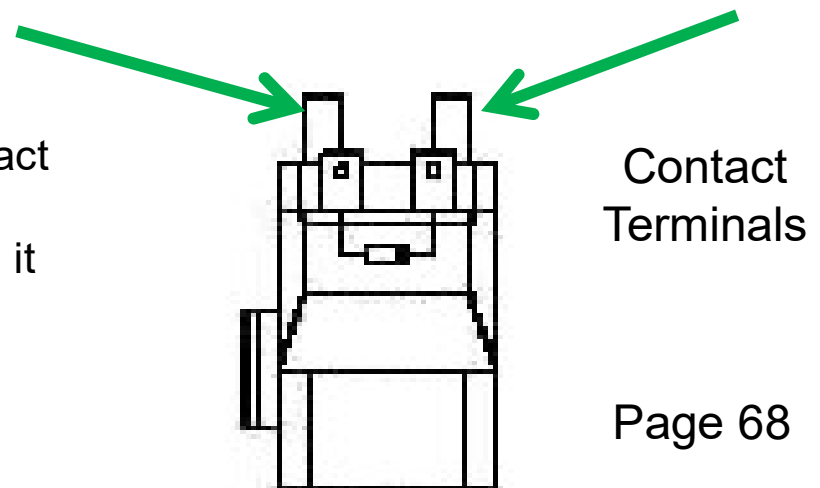

19.4 Testing the Drive System Potentiometer

1. Disconnect the potentiometer from circuit
2. Use ohm meter (preferably an analog type) to measure the resistance across the two outside terminals (Fig. 1). It should measure 5K (5,000 ohms +/- 20%)
3. Measure the resistance from the center terminal to each outside terminal.
Fig. 2 and Fig. 3) The resistance should show a smooth change while turning the shaft on each.

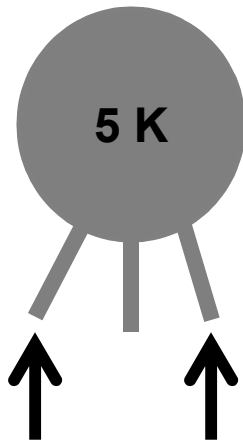

5K Fixed Value
Does not
change while
turning shaft
Fig. 1

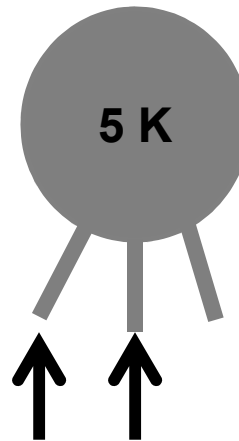

5K to 0K
Variable
Resistance
Adjust shaft
while testing
Fig. 2

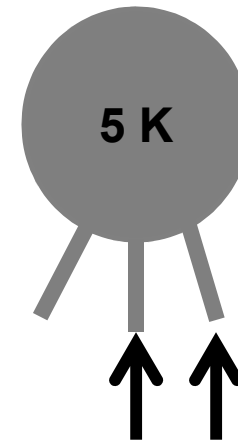

0 to 5K Variable
Resistance
Adjust shaft
while testing
Fig. 3

20. Current Draw of Motors

Test	Min	Nom	Max
Rated Voltage: 24vdc	22	24	30
Brush Motor Current: @ No Load (without brush)	3.0	4.0	6.0
Brush Motor Current: with brush	12.0	14.5	17.0
Total Machine Current: with brush	29.0	33.5	36.0
Vac Motor Current	16.0	18.0	20.0
Water Lift Through Squeegee	10.0	13.0	17.0
Water Lift Sealed at Squeegee Hose	41.0	47.0	53.0

21. Notes

